



ENTRY DOOR DECORATIVE HANDLESET AND DUMMY HANDLE INSTALLATION INSTRUCTIONS

BEFORE YOU BEGIN

Check the thickness of the door. The handle will work with a door 1-3/4" thick only. If door thickness is greater than 1-3/4" up to 2-1/4", please contact Pella Corporation.

Note

- If your door is pre-bored, go to Step 1 for handle installation. If your door is not pre-bored, go to Step 2 and 3 for preparing the door for handlesets and strikes.
- The deadbolt and latch for this handleset have an adjustable backset. Both latches and deadbolts are preset to a 2-3/8" backset. Only adjust the latches and deadbolts if your door is pre-bored, to a 2-3/4" backset.

TOOLS REQUIRED:	ADDITIONAL TOOLS IF DOOR IS NOT PRE-BORED:		
<ul style="list-style-type: none"> • Phillips screwdriver  or power screwdriver  	<ul style="list-style-type: none"> • Center punch  • 1/8" drill bit  • 3/8" drill bit  • 7/8" spade bit  	<ul style="list-style-type: none"> • Wood chisel  • 2-1/8" hole saw  	<ul style="list-style-type: none"> • 1" spade bit  • Drill 

PART IDENTIFICATION

ENTRY DOOR SINGLE CYLINDER HANDLESET

- Adjustable deadbolt
- Adjustable latch
- Flat head wood screws
- Key
- Key cylinder
- Cylinder backplate
- Turnpiece mounting plate
- 2" Pan head machine screws
- Turnpiece trim
- 7/8" Oval head machine screws
- Exterior handle assembly
- Thumbpiece cartridge
- Spindle
- Spindle Collar
- Adapter
- 1- 1/4" Flat head machine screws
- Internal trim plate
- Plastic washer
- Lever
- Set screw
- Screw cover washer
- 2-1/2" Flat head machine screw
- Screw cover
- Tapping screw
- Deadbolt strike
- Latch strike
- Deadbolt strike screws

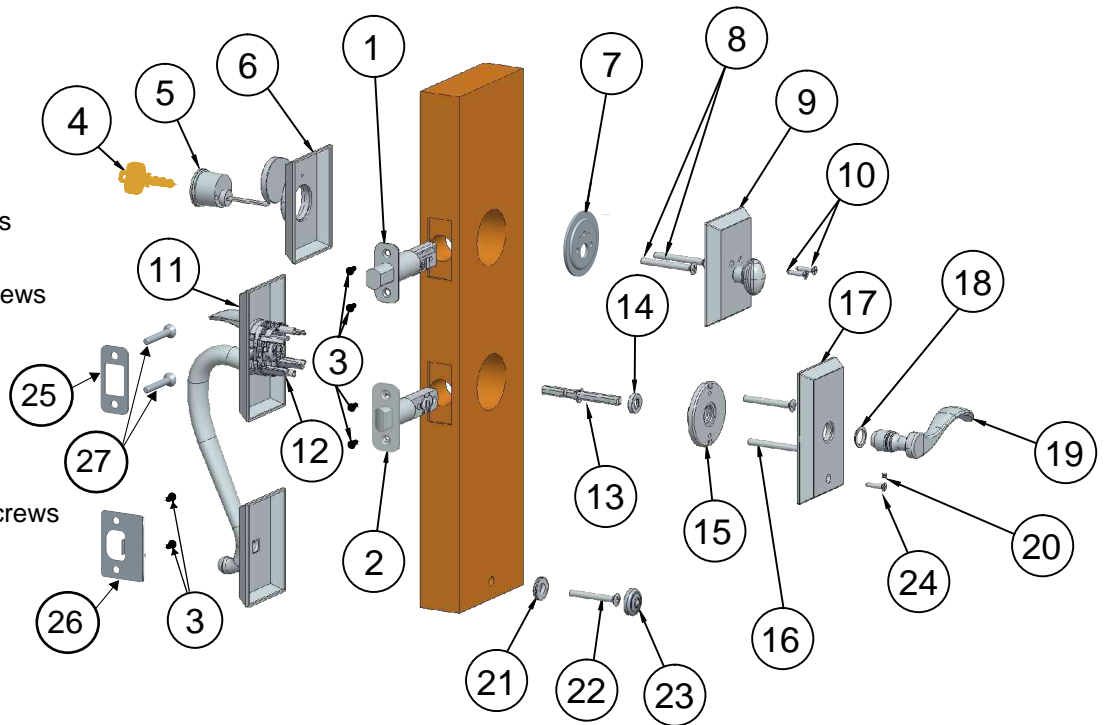

INSTALLATION FASTENERS

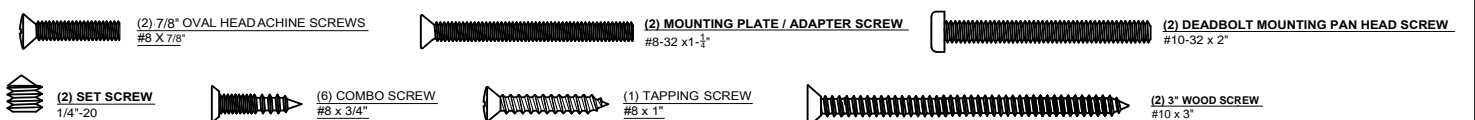

1 HANDLE INSTALLATION

- A. Using the marking template for handleset, mark hole E and drill 3/8" hole as specified.**

Note: Even if your door is pre-bored you still need to drill this hole to secure the bottom of your handleset. Refer to Step 2C for additional information.

- B. Install the deadbolt into the door panel.** Insert the deadbolt into the top bore ensuring the "+" slot is underneath and ridge on top. Using a 1/8" drill bit drill two pilot holes and secure the deadbolt with two flat head wood screws. Ensure the bolt is extended for installation.

Note: To extend the head of the deadbolt, insert a screwdriver into the "+" slot and rotate.

- C. Insert the latch into the door panel.** Insert the latch into the bottom bore ensuring the curved side of the latchbolt is facing the door jamb. Using a 1/8" drill bit to drill two pilot holes. Secure the latch with two flat head wood combo screws.

- D. Slip the spindle collar onto the long end of the spindle** with the flat side of the collar facing the spindle e-ring.

- E. From the interior of the door insert the spindle.** Insert the short end of the spindle through the latch with the groove side of the long end facing down.

- F. Place the exterior handle assembly into position.** Holding the spindle in place from the interior, slide the turnpiece cartridge of the handle assembly onto the spindle.

- G. Hold the exterior handle assembly in place** and position the mounting plate/adaptor on the inside of the door. Drive two 1-1/2" machine screws through the adapter and into the thumbpiece cartridge. **DO NOT OVER TIGHTEN SCREWS.**

- H. Install the key cylinder.** Keeping the tailpiece vertical, insert the key cylinder through the exterior handle assembly and into the "+" slot of the deadbolt. Secure the exterior cylinder by driving two 2" pan head machine screws through the mounting plate, deadbolt and into the exterior cylinder.

DO NOT OVER TIGHTEN SCREWS AND DO NOT INSERT KEY INTO KEY CYLINDER DURING THIS STEP.

- I. Remove the screw cover washer from the screw cover.** Insert the 2-1/2" flat head machine screw through the chamfered hole in the screw cover washer. Drive the screw with the washer through the door and into the bottom of the exterior handle assembly. Tighten screw and install screw cover washer.

- J. Install the turnpiece trim.** Position the turnpiece trim over the mounting plate, inserting the key cylinder tailpiece into the turnpiece. Secure in place by driving two 1/2" oval head machine screws through the two chamfered holes.

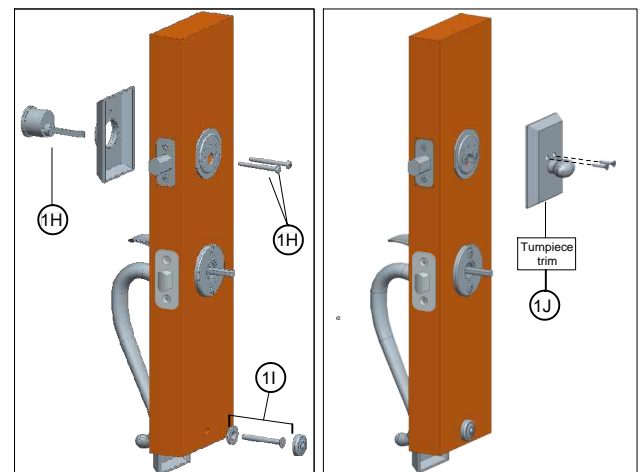
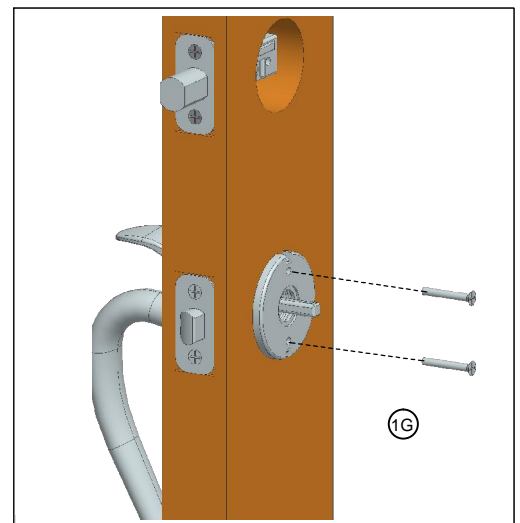
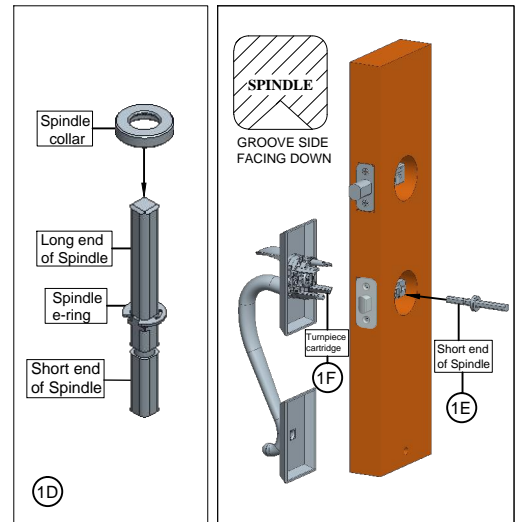
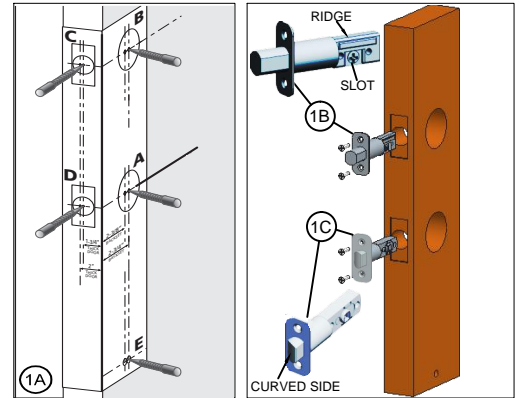

- K. Place the external trim plate** which clasps onto the mounting plate adapter.
- L. Place the plastic washer on the shank of the lever.**
- M. Install lever.** Slide the lever onto the spindle. Make sure there is not a gap between the knob/lever and the trim plate. Insert and tighten the set screw with the allen wrench provided.
- N. Secure the internal trim plate with the tapping screw provided.**

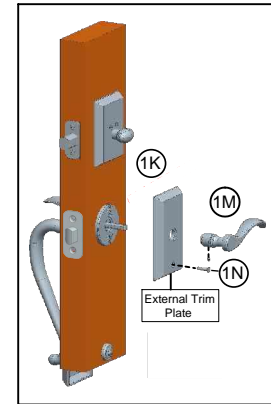
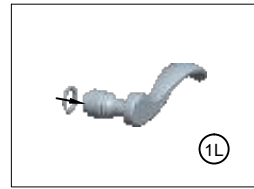

2 PREPARING DOOR FOR HANDLESETS

Note: The following instructions are for doors that have not been pre-bored ONLY.

Note: To prepare the door for DUMMY HANDLESET perform Steps A thru B, excluding the door edge marking and boring.

- A. Fold the marking template for handleset on the line** and place on the door at the specified height (approximately 38" from the floor). Use a center punch to mark the hole locations on the face (A thru E) and edge (C and D) of the door panel.

Caution: RE-CHECK bore hole locations BEFORE drilling.

- B. Drill the face bores and edge bores** as indicated on the template.

- C. Drill the 3/8" lower pull assembly hole E** as indicated on the template.

- D. Insert the deadbolt into the edge hole C of the door.** Trace an outline of the faceplate onto the door's edge and mark the screw hole centers.

- E. Insert the latch into the edge hole D of the door.** Trace an outline of the faceplate onto the door's edge and mark the screw hole centers.

- F. At the screw hole marks, drill two 1/8" diameter pilot holes** for the screws.

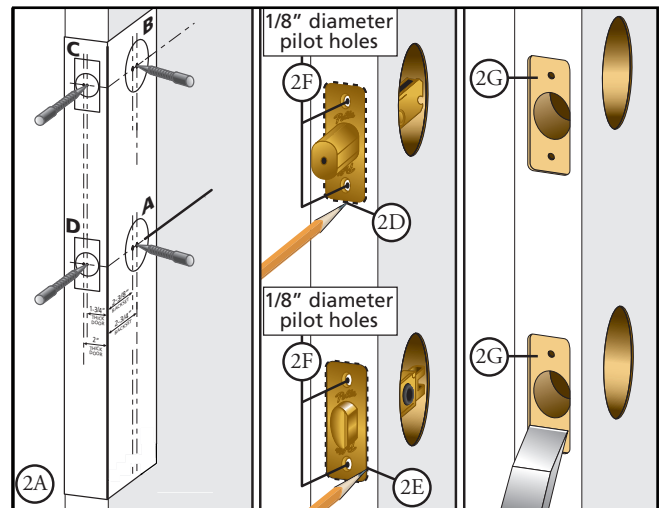

- G. Chisel out the area marked in Steps 2D and 2E** to a depth of 1/8" or until the faceplates are flush with the door's edge.

3 PREPARING DOOR FOR STRIKE INSTALLATION

Note: Dummy handleset does not require strike installation.

- A. Using the marking template for strikes** locate and use a center punch to mark the strike mounting screws and centering points for both strikes at the required door thickness.

- B. Align and trace the outline of both strikes** onto the door frame using the mounting screw marks for location.

- C. At the screw marks,** drill 1/8" diameter pilot holes for the screws.

- D. At the centering point mark,** bore a 7/8" diameter by 1" deep hole.

- E. Chisel the areas mark in Step B** until the strikes are flush with the door frame.

- F. Place the strikes** and secure with the screws provided.

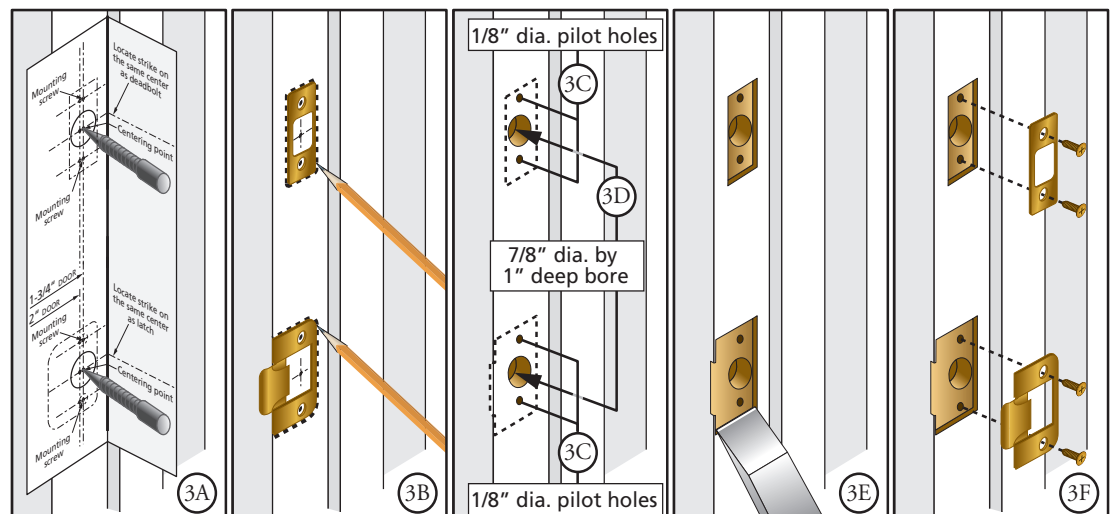

4 DUMMY HANDLESET

Note: For dummy function installation use the parts included. These parts will substitute the similar entry function parts.

PART IDENTIFICATION

1. Dummy cylinder
2. Exterior handle assembly
3. Cylinder backplate
4. Dummy bracket
5. Turnpiece mounting plate
6. Dummy adapter
7. 2" Pan head machine screws
8. 1-1/4" Flat head machine screws
9. Turnpiece trim
10. Internal trim plate
11. 1/2" Flat head machine screws
12. Plastic washer
13. Knob/lever
14. Set screw
15. Screw cover washer
16. 2-1/2" Flat head machine screw
17. Screw cover
18. Wood screw
19. Dummy bracket screw

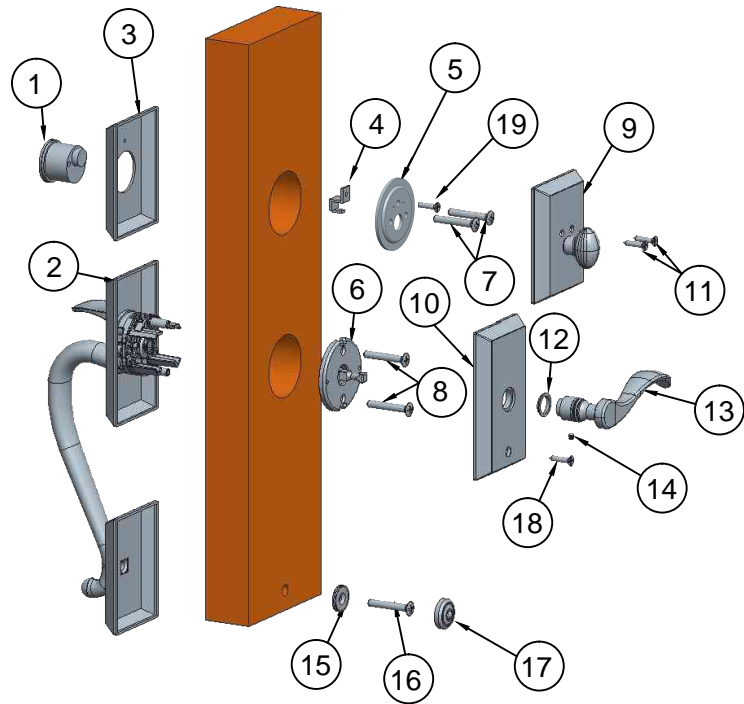

A. Using the marking template for handleset, mark hole E and drill 3/8" hole as specified.
Note: Even if your door is pre-bored you still need to drill this hole to secure the bottom of your handleset. Refer to Step 2C for additional information.

B. Place the exterior handle assembly into position.

C. Position the dummy adapter on the inside of the door. Drive two 1-1/2" flat head machine screws through the dummy adapter and into the exterior handle assembly.
DO NOT OVER TIGHTEN THE SCREWS.

D. Attach the dummy bracket onto turnpiece mounting plate. Secure the dummy bracket onto the turnpiece mounting plate by driving the dummy bracket screw through the turnpiece mounting plate and into the dummy bracket.

E. Install the dummy cylinder. Insert the dummy cylinder through the cylinder backplate and into the door. Secure the dummy cylinder by driving two 2" pan head machine screws through the mounting plate and into the dummy cylinder.
DO NOT OVER TIGHTEN THE SCREWS.

F. Remove the screw cover washer from the screw cover. Insert the 2-1/2" flat head machine screw through the chamfered hole in the screw cover washer. Drive the screw with the washer through the door and into the bottom of the exterior handle assembly. Tighten screw and install screw cover.

G. Install turnpiece trim. Position the turnpiece trim plate over the mounting plate. Inserting the dummy bracket into the turnpiece trim. Secure the plate by driving two 1/2" oval head machine screws through the two chamfered holes.

H. Place the plastic washer on the shank of the lever.

I. Install internal trim plate and lever. Snap the internal trim plate onto the adapter. Slide the lever onto the spindle. Make sure there is not a gap between the knob/lever and the turnpiece trim plate. Insert and tighten the set screw with the Allen wrench provided.

