

Rekeying of Cylinders

Key blanks at the store: Schlage (SC1) or Weiser depending upon original order.

1. Disassemble cylinder from door.
2. key and test core. If they fit properly, continue to Step 3.
3. Unscrew the allen screws and remove existing pins and springs from the cylinder core slots.
4. Place new core pins and springs back into the appropriate cylinder core slots.
5. Replace allen screws and re-assemble cylinder to door.

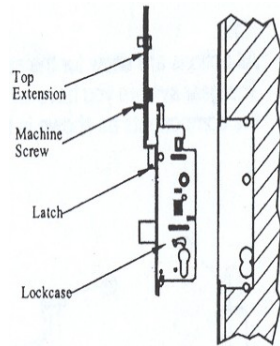

Diagram A

4. Remove machine screw in top of lock case. Slide top extension into place and fasten to lock case with the supplied machine screws to door edge. Use #6 screws. The #6 screws should be screwed in flush with the faceplate, but not over tightened. Test gear with the door in the open position. Engage system by lifting handle (note if multipoint system operates on the edge of the door) and extend deadbolt by turning thumb turn. If the system operates on the door edge and the deadbolt operates, the hardware system in the door is fully functional. If not, please see the Troubleshooting Guide.

PLEASE NOTE: MAIN GEAR AND EXTENSIONS SHOULD BE HAND-TIGHTENED ONLY. EXCESSIVE FORCE MAY CAUSE DRIVE RAIL TO BIND AND INHIBIT SYSTEM OPERATION.

Swing Door Handle Set Installation Instructions

A Phillips screwdriver is required.

A Hex wrench for set screws is provided in the hardware package.

To prevent damage to the handle set while in construction phase, use a construction handle to operate the door. Lift to engage multipoint to close door. Push down to open the door.

Use water to clean. Do not use brass cleaner as it will remove the protective coating.

Note: Handles and back plates vary by style but application is the same.

1. Apply the back plate gasket to the inside of the exterior back plate. Push gasket firmly onto place to ensure a tight seal. Apply the back plate gasket to the inside of the interior back plate. Apply interior and exterior back plates and fasten loosely with the two screws provided. Note: The screw heads must be on the interior side of the door.
2. Insert the one piece handle shaft into the handle. Be sure to orient the shaft as shown below. Screw the set screw until flush with handle using the hex wrench provided. Insert the nylon bushings onto the handle then insert the handle into the latch hole.
3. Install the interior handle on the shaft through the latch hole, pressing both handles tightly to the back plates. Tighten the interior handle set screw with allen wrench. Screw until flush with handle.
4. Insert the keyed cylinder from the interior side of the door until it is flush with the exterior back plate. Install the cylinder screw in the screw hole below the deadbolt in the edge of the door.
5. Tighten the back plate screws.

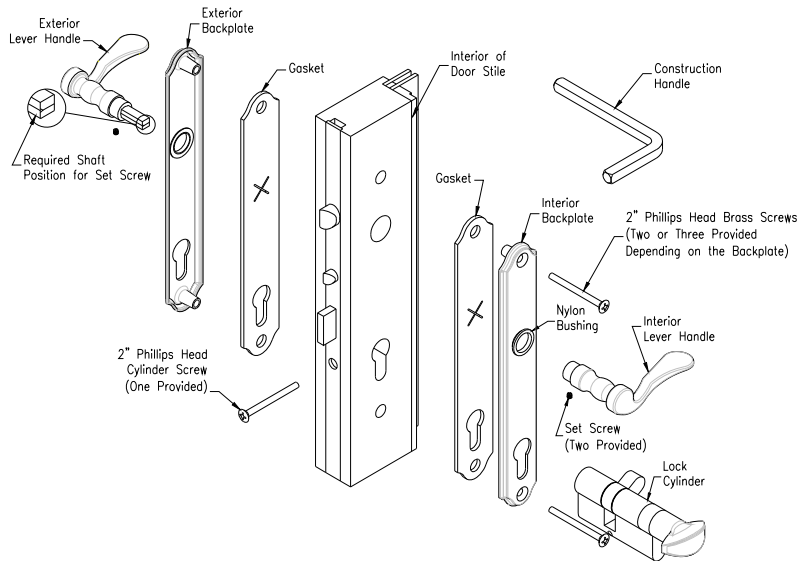

6. INTERFERENCE OF STYLE WITH HANDLE

Probable Cause: Cladding or wood in the hole is interfering with shaft.

Solution: Check to see if machined holes line up with screw and handle holes. May need to file or drill hole slightly larger.

7. SET SCREWS WILL NOT GO INTO HANDLE COMPLETELY

Probable Cause: Shaft is not assembled properly.

Solution: Remove handle to see how shaft is assembled. See Handle Set Installation Instructions for proper assembly and position of shaft.

8. BOTTOM LOCKING POINT MOVES BUT TOP LOCKING POINT DOES NOT

Probable Cause: Top extension drive rail is not connected at the lock case.

Solution: Remove screws used to attach top extension to the door and the machine screw that attaches it to the lock case, and

remove top extension. Place the end of the drive rail (the “L” shape) in the lock case above the latch bolt, as you slide the top extension into the door. Fasten with a screw at the lock case and the one up higher. Operate the gear to make sure it works. Then finish installing the rest of the screws.

9. IF DOOR HAS PLAY OR IS NOT SEALING CORRECTLY

Probable Cause: Unit is not adjusted properly.

Solution: Bend tab on strike.

10. KEY DOES NOT WORK IN CYLINDER

Probable Cause: Cylinder was rekeyed incorrectly.

Solution: Check with Builder or Installer to see if cylinder was rekeyed to match other doors in the house. If so, return to locksmith to rekey properly.

Installation of Multipoint Swing Door Hardware

1. When the door is in the open position, the bevel on the latch should push the latch into the lock case when you close the door. If you need to reverse the latch, see Hardware Adjustment Sheet.
2. Slide main gear (shown in drawing) into place aligning holes drilled in door face with cylinder, handle holes and lock case to properly accommodate trim.
3. Install handle set per Swinging Patio Door Handle Set Installation Instructions.