

9" MULTIPOINT TRIM INSTALLATION INSTRUCTIONS

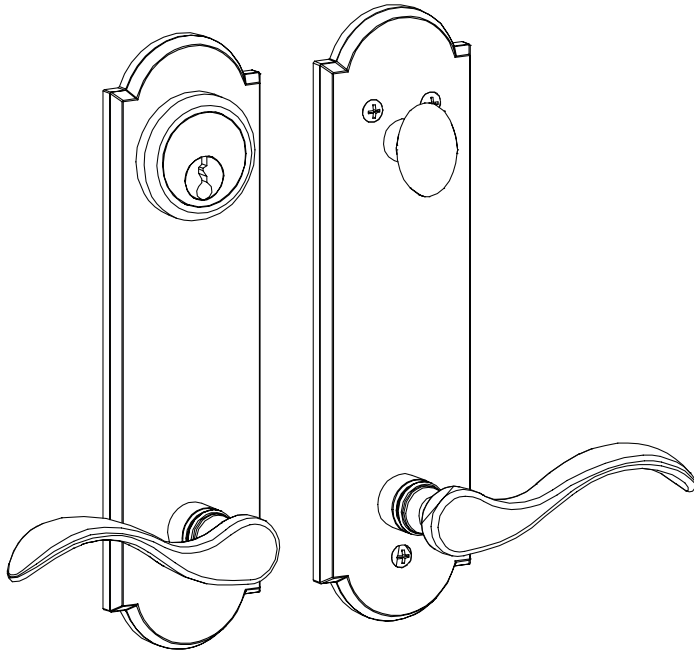

Tools Required

- Phillips screw driver
- Allen Wrench (provided)

Exploded View 9" Multipoint Trim

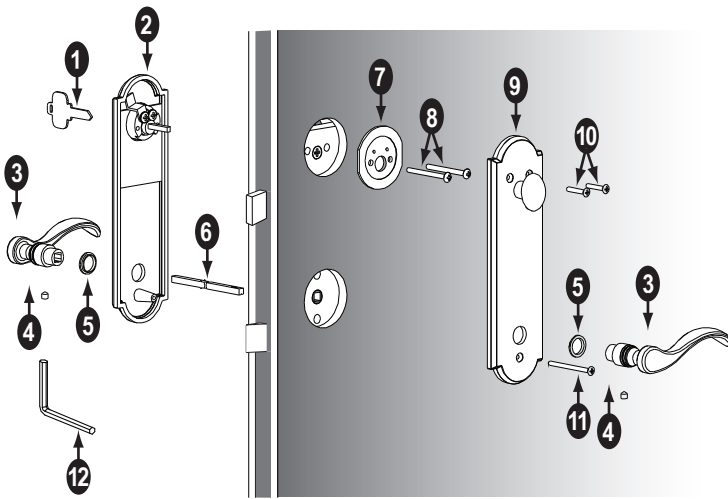

- | | |
|---------------------------|----------------------------------|
| 1. Key | 7. Deadbolt mounting plate |
| 2. External trim assembly | 8. 2" Pan head machine screw |
| 3. Lever | 9. Interior trim |
| 4. Set screw | 10. 7/8" Oval head machine screw |
| 5. Nylon washer | 11. 2" Oval head machine screw |
| 6. Spindle | 12. Allen wrench |

1. TRIM SET INSTALLATION INSTRUCTIONS

A. **Determine the handing of door** . Standing on the outside of the door if the hinges are to the left of the door then the door is left handed and if the hinges are to the right of the door then the door is right handed.

INSIDE (Room or House)

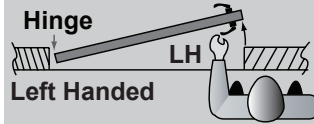

OUTSIDE (Room or House)

INSIDE (Room or House)

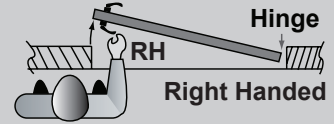

OUTSIDE (Room or House)

B. **Determine the cylinder tailpiece orientation** . Without the key inserted into the cylinder, fully rotate the tailpiece clockwise for left handed door and fully rotate the tailpiece counterclockwise for right handed doors. **NOTE: Improper orientation of the tailpiece may cause the deadbolt not to function properly.**

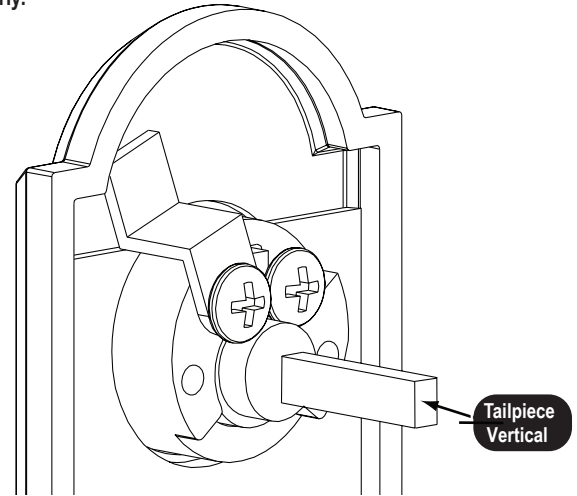

C. **Install the cylinder** . From the outside of the door, with the cylinder tailpiece oriented vertical, insert the tailpiece into the "+" slot of the deadbolt. Secure the exterior trim assembly by installing the two 2" pan head machine screws through the deadbolt mounting plate and into the cylinder housing.

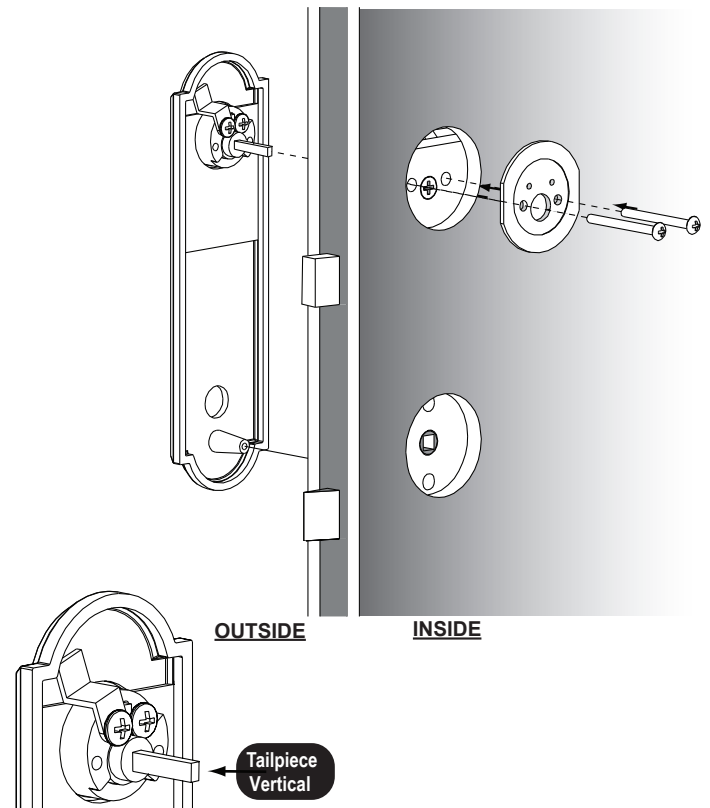

1. TRIM SET INSTALLATION INSTRUCTIONS – cont.

D. From the exterior of the door insert the spindle with the groove side down and the stamped arrow facing towards the square hole of the latch. Slide the spindle through the latch until the stops of the spindle are flush with the lock body.

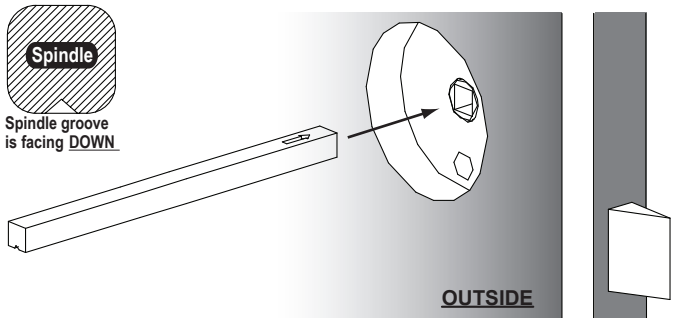

E. Install the interior trim by positioning the interior trim over the mounting plate insert the cylinder tailpiece into the turnpiece of the interior trim. Secure the interior trim in place by installing the two 7/8" oval head machine screws through the top two screw holes and the 2" oval head machine screw the bottom screw hole on the interior trim.

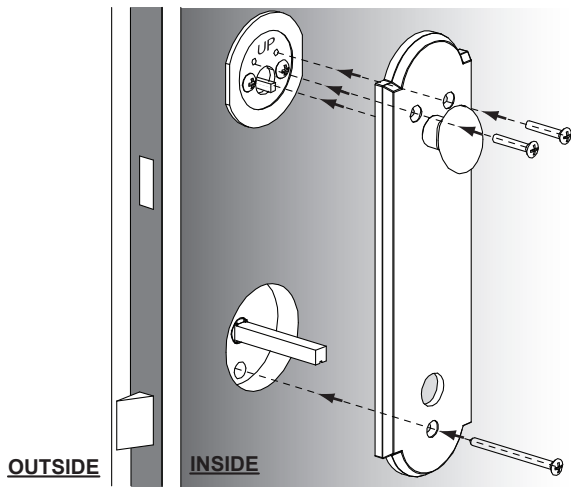

F. Place the plastic washers on the shanks of both levers

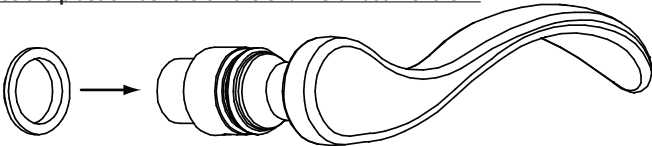

G. Slide the interior lever onto the spindle, while pushing the spindle from the outside of the door at the same time. Make sure there is no gap between the interior trim and lever. Insert and tighten the set screw with the Allen wrench provided.

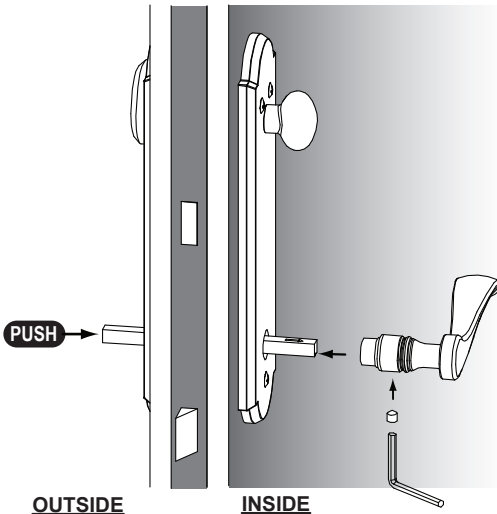

1. TRIM SET INSTALLATION INSTRUCTIONS – cont.

H. Slide the interior lever onto the spindle, while pushing the spindle from the outside of the door at the same time. Make sure there is no gap between the interior trim and lever. Insert and tighten the set screw with the Allen wrench provided.

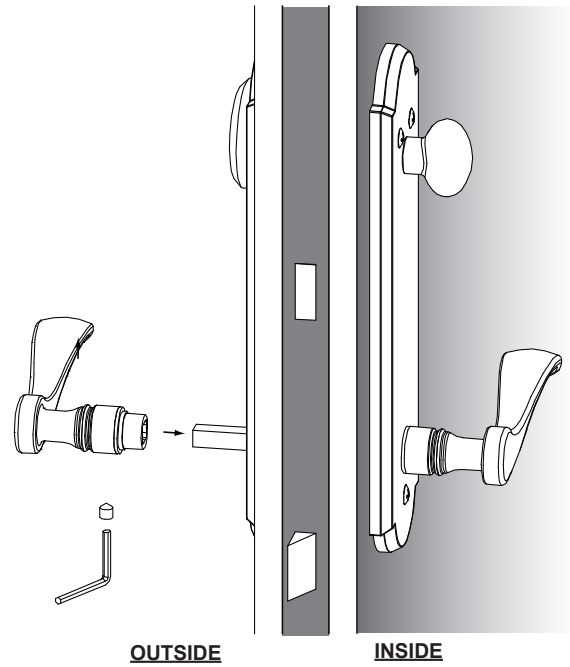

I. Ensure the levers are oriented correctly

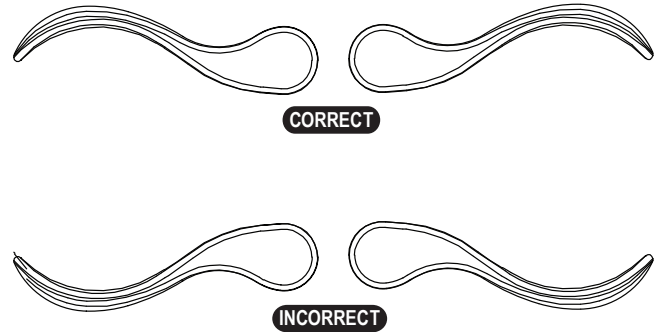

TROUBLE SHOOTING GUIDE

PROBLEM	SOLUTION
Can not extend (lock) deadbolt unless key is in cylinder. Can not remove key from cylinder when the deadbolt is extended (locked).	Cylinder tailpiece is not oriented properly. Remove the cylinder and rotate the cylinder tailpiece 180° and re-install the trim set. Refer to steps 1A through 1H.
Lever(s) keeps coming off the spindle	Ensure the spindle is oriented with the groove facing down and the set screw is securely tightened. Refer to step 1D.
Lever rotates freely and does not retract the latch.	Spindle is not inserted fully. Ensure stop of spindle are flush with the lock. Refer to step 1D.
Deadbolt can easily be lock using the turnpiece trim on the inside but is difficult to lock when locked with the key from the outside.	The cylinder is not properly aligned with the turnpiece trim or improper door thickness. Remove the exterior trim and loosen the two 2" pan head machine screw. Align the cylinder and retighten the 2" pan head screws. Ensure your door thickness is at least 1-3/4" thick.
Can not extend deadbolt with the interior thumb turn or exterior key when door is closed.	Open door and try to extend deadbolt. If deadbolt extends easily with the door open then the strike are not aligned with the deadbolt and/or locking points. Adjust the strike to align with the deadbolt and/or locking points.
Lock is not working properly	1. Screws on the faceplate of the lock are too tight and causing the moving rail to bind. Loosen the screws on the faceplate of lock. 2. Remove debris from route which may be blocking the moving rail.