

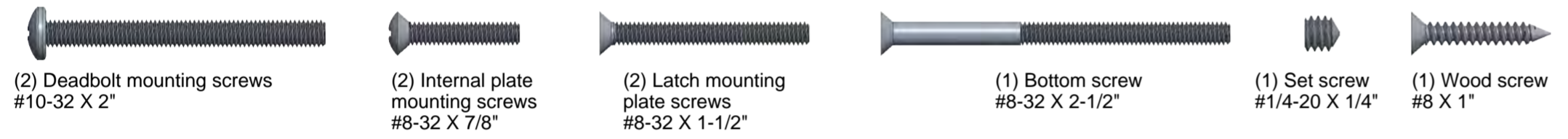

# MULTIPOINT HANDLE SET INSTALLATION INSTRUCTIONS

1. Key
2. Wood Screw
3. External Pull Assembly
4. Deadbolt Mounting Plate
5. Deadbolt Mounting Screws
6. Spindle
7. Spindle Collar
8. Latch Mounting Plate
9. Latch Mounting Plate Screws
10. Internal Plate Assembly
11. Plastic Washer
12. Lever
13. Set Screw
14. Allen Key
15. Right Hand Spindle Cartridge  
(Left Hand Spindle Cartridge  
Pre-installed)
16. Wave Washer
17. Bottom Screw
18. Bottom Screw Washer
19. Internal Plate Screws

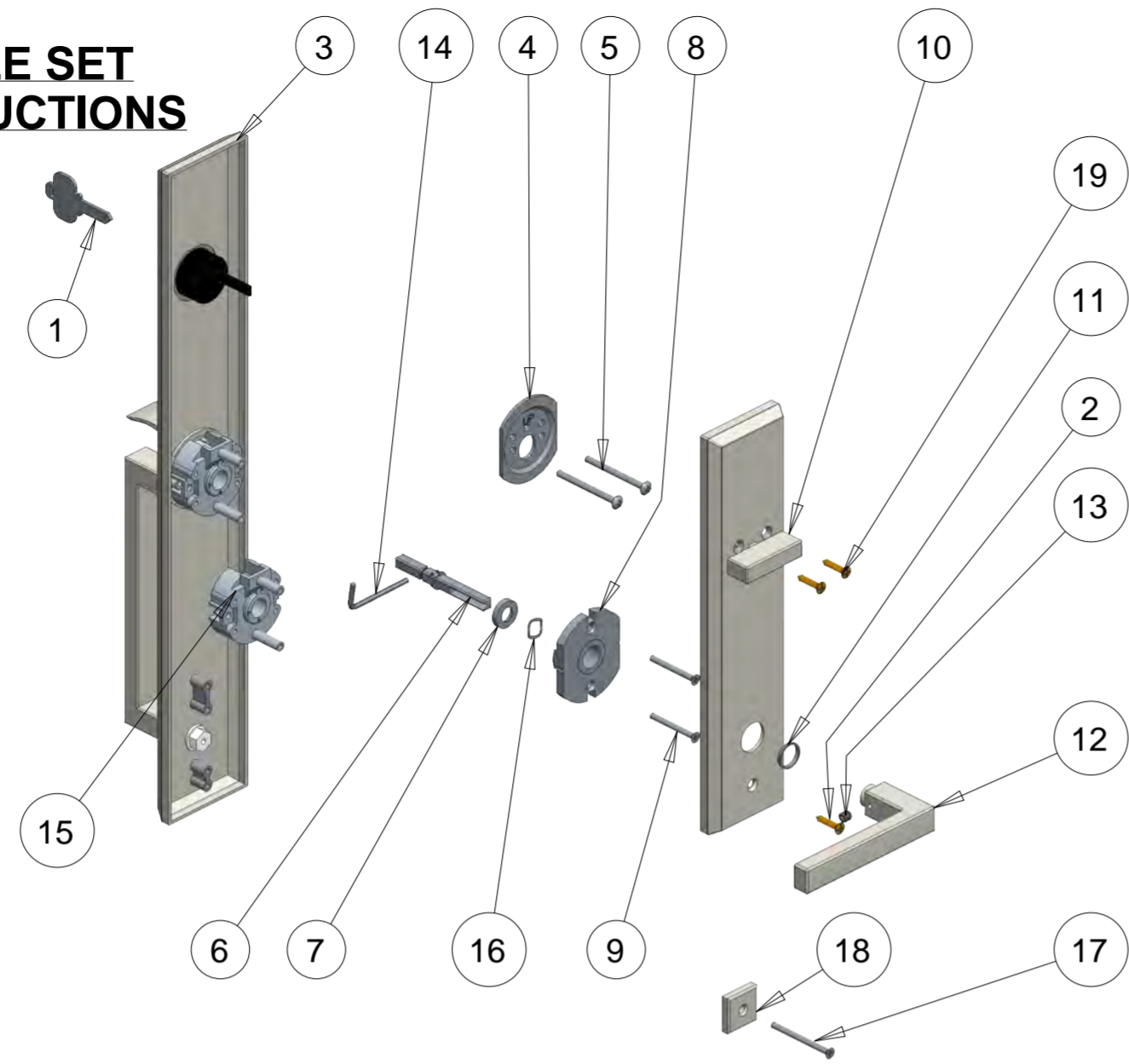

## BEFORE YOU BEGIN

Check door thickness as handle will work with a 1-3/4" thick door only. If door thickness is greater than 1-3/4" up to 2-1/4" thick please contact Rockwell Security Inc. Follow step by step installation instructions to ensure proper operation of handle set.

## REQUIRED TOOLS

- Protective Eyewear
- #2 Phillips Screwdriver
- Pencil
- 3/8" Drill Bit

Always wear protective eyewear.

**1. Door Preparation**  
**A.** Measure thickness of door. Ensure door is at least 1-3/4" thick. If door thickness is less than 1-3/4" **DO NOT PROCEED WITH INSTALLATION.**  
**B.** Fold the marking template for the handle set on the line and place on the door aligning A and B of the template with the double bore of door. Locate and mark hole E with a pencil. Carefully drill hole E perpendicularly (at a 90°) to door with a 3/8" drill bit. **IMPORTANT: Double check hole E location before drilling.**

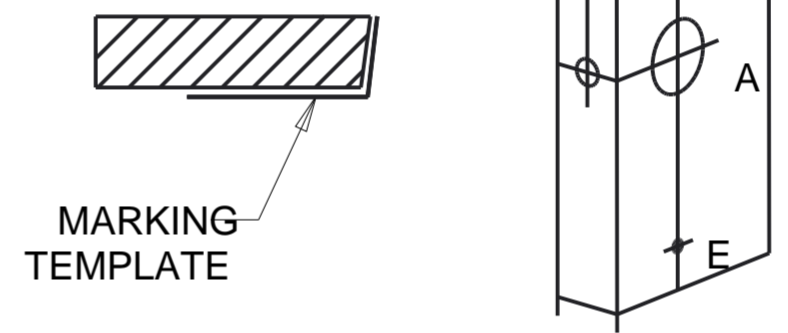

**2. Determine the handing of your door.** Standing on the outside of the door, if the hinges are to the left of the door then the door is left handed and if the hinges are to the right of the door then the door is right handed. Handle sets are supplied with left and right hand spindle transmissions to work on both left and right hand doors

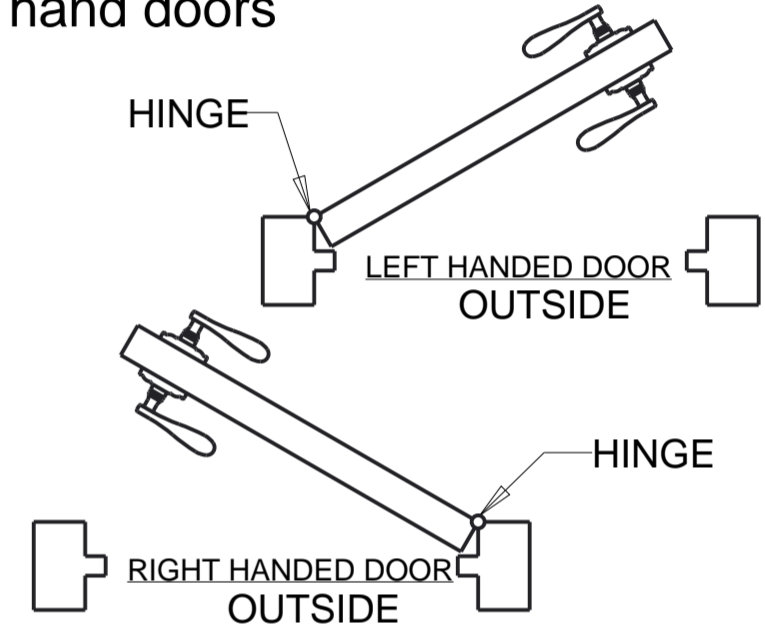

**3. The handlesets are preset to work with a Left hand door, should you have a right hand door, the left handed spindle cartridge will need to be switched to a right hand spindle cartridge. Right Hand Spindle Cartridge (included) has instructions on changing from left to right hand. For Left hand doors please proceed to step 4. For Right hand doors, please replace the spindle cartridge to the correct hand prior to proceeding to step 4. The handle set will not work if the incorrect cartridge is installed.**

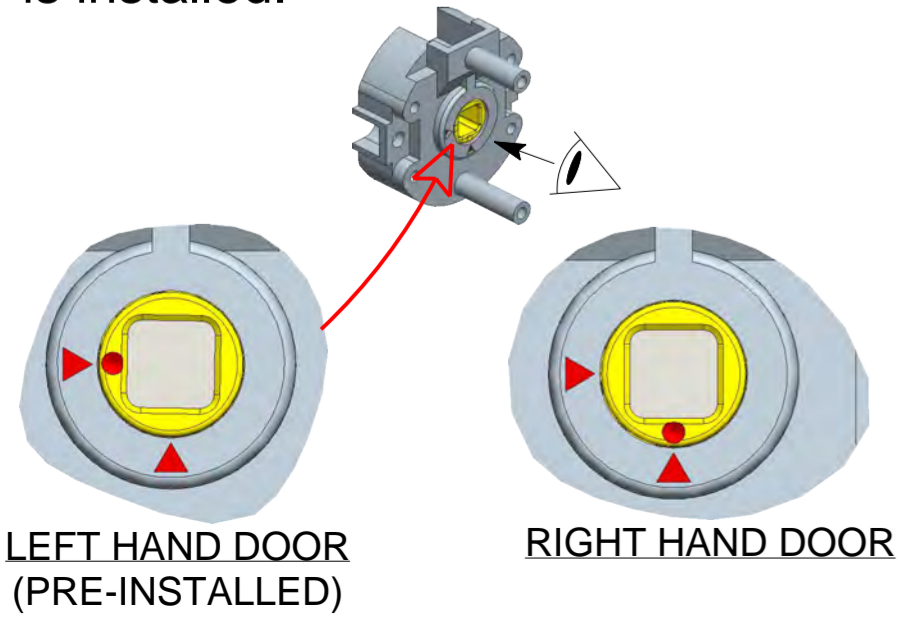

**4. Extend the deadbolt of the lock by inserting the Phillips screwdriver into the cross slot and turning.**



**5. Insert from the inside of the door the short end of the spindle into the latch hub of the lock, ensuring the groove side of the long end of the spindle is facing door hinge. Slide the spindle collar and the wave washer onto the long end of the spindle. Only use 1 wave washer. Kit includes a spare wave washer.**

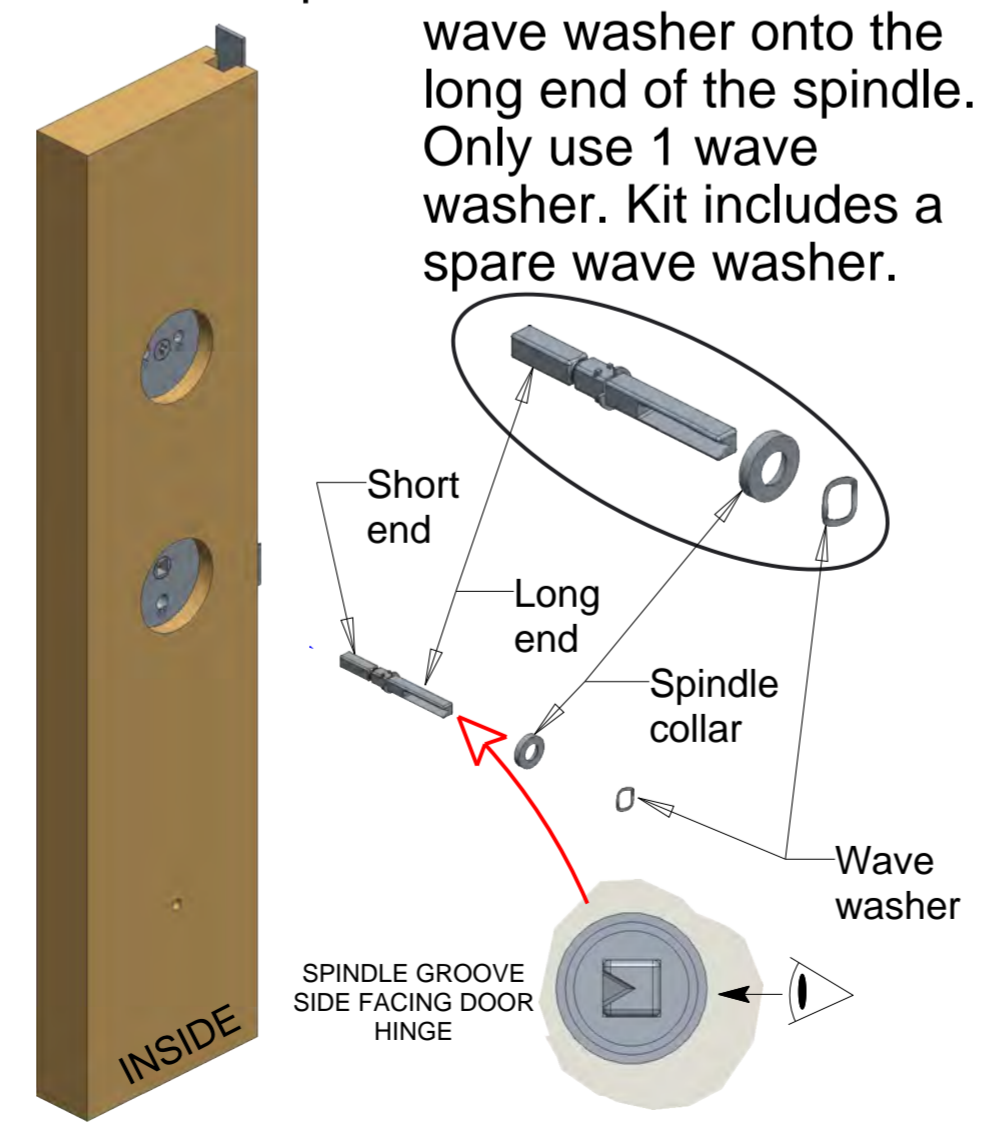

**6. Keep the tailpiece of the cylinder vertical. Engage the tailpiece in the lock first. The external assembly will need to be at an angle with the door. DO NOT INSERT THE KEY INTO THE CYLINDER DURING THIS STEP.**

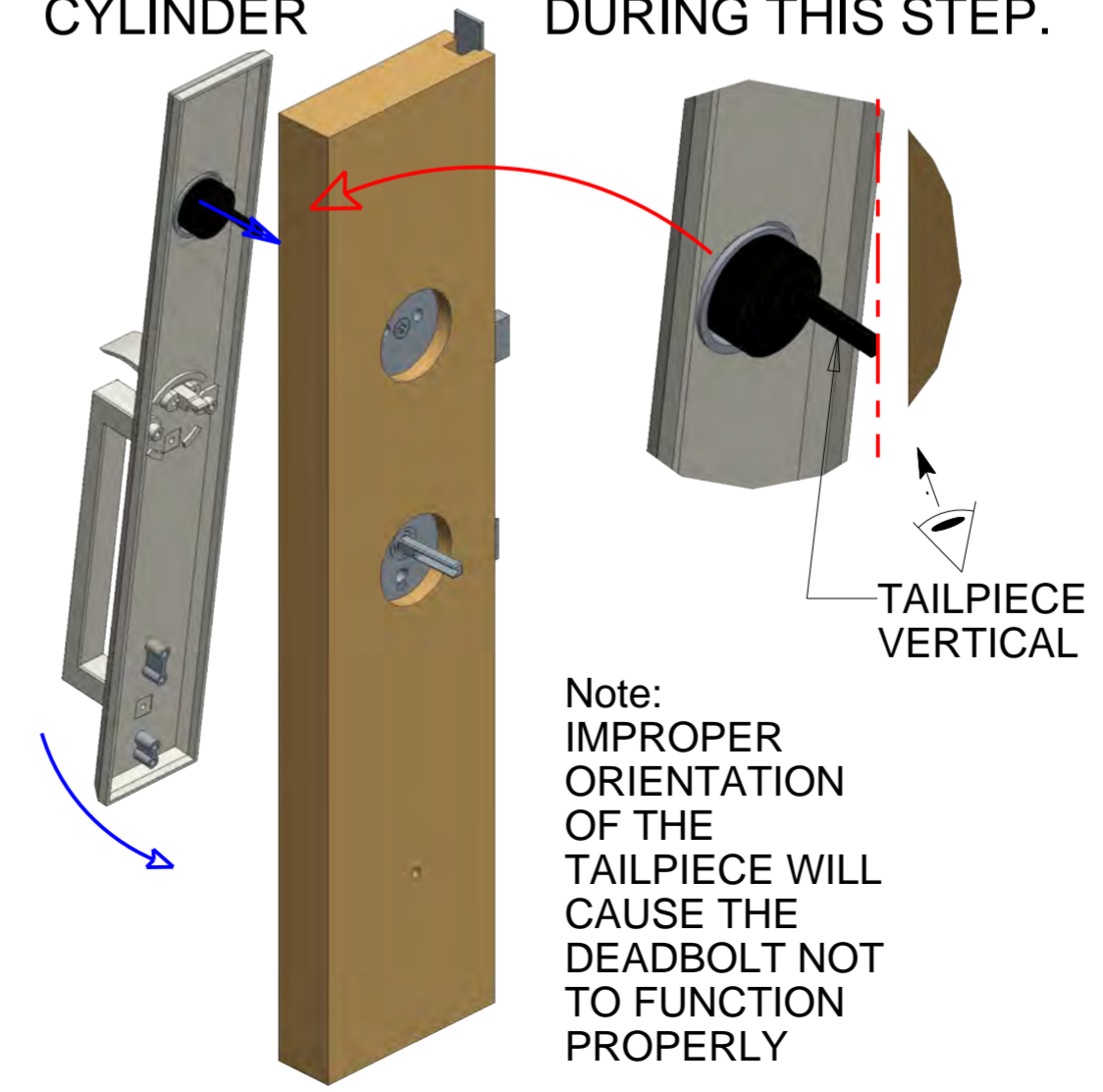

**7. Keep the tailpiece of the cylinder engaged in the lock. Hold the spindle from inside and slide the cartridge of the external pull onto the spindle. The pull assembly might need to rotate slightly in all directions.**

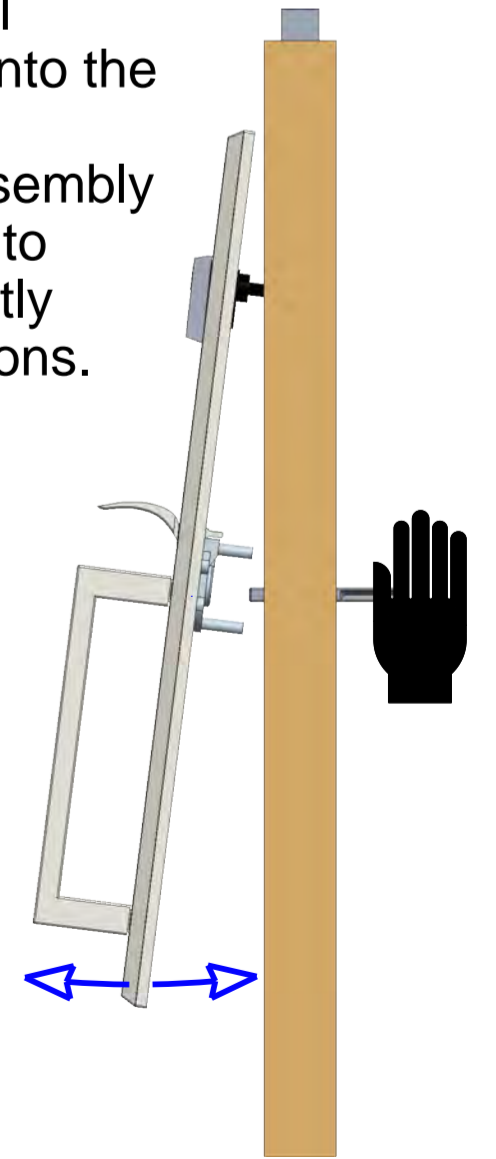

8. From the inside of the door orient the deadbolt mounting plate and secure by inserting the two deadbolt mounting screws through the deadbolt mounting plate, lock, and into the cylinder housing. Install bottom screw with screw washer. Tighten the 2-1/2" flat head machine screw. **DO NOT OVER TIGHTEN MOUNTING SCREW.**

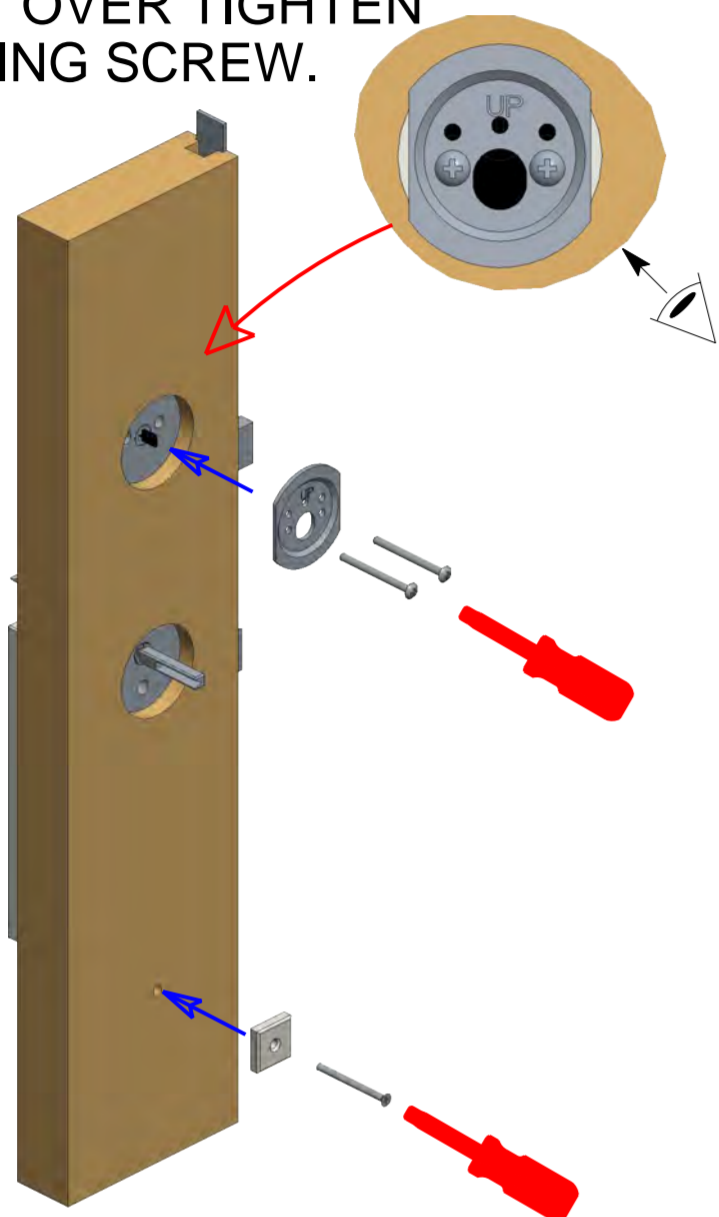

9. Slide the mounting plate onto the spindle. Secure the latch mounting plate using the two latch mounting plate screws.

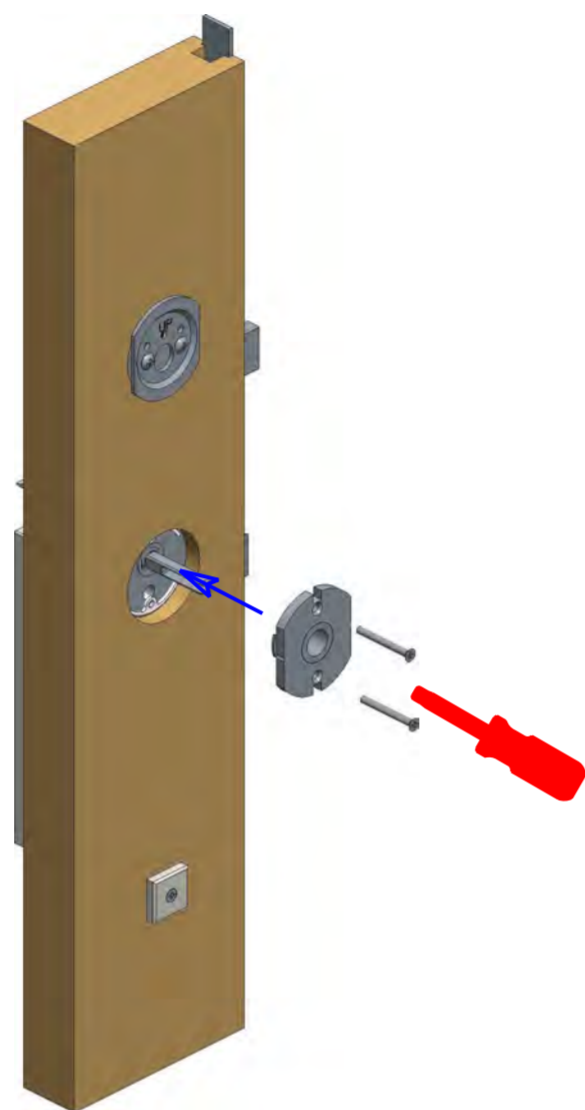

10. Position the internal plate assembly over the mounting plate and insert the cylinder tailpiece into the thumbturn of the internal plate assembly. Ensure the Thumbturn is horizontal.

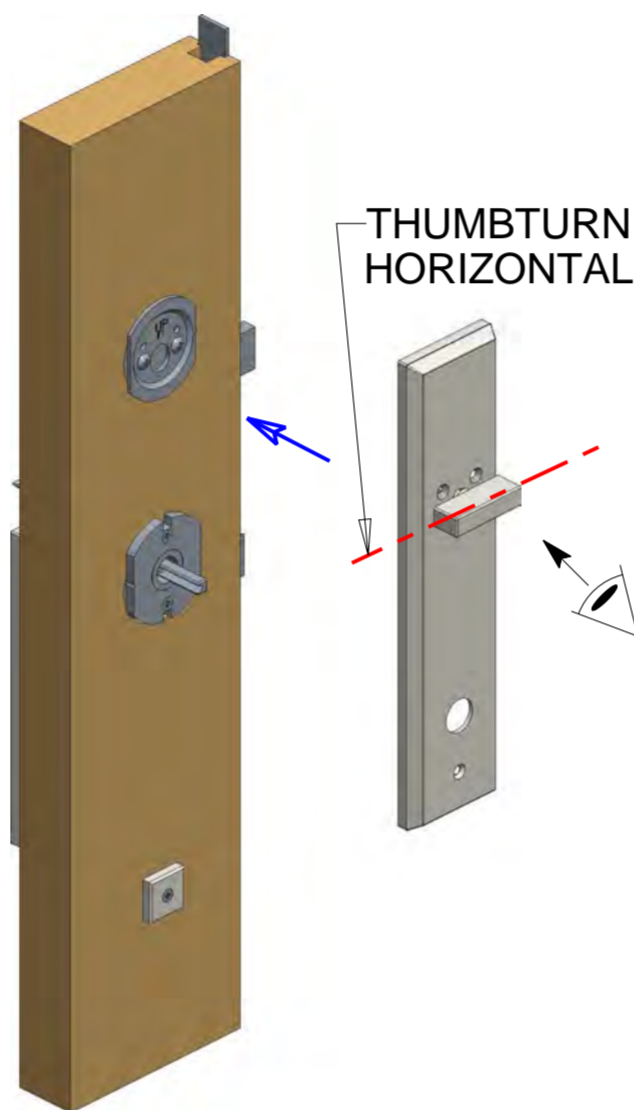

11. Place the plastic washer on the shank of the lever. Test operation of the thumbturn and thumbpiece prior to proceeding further.

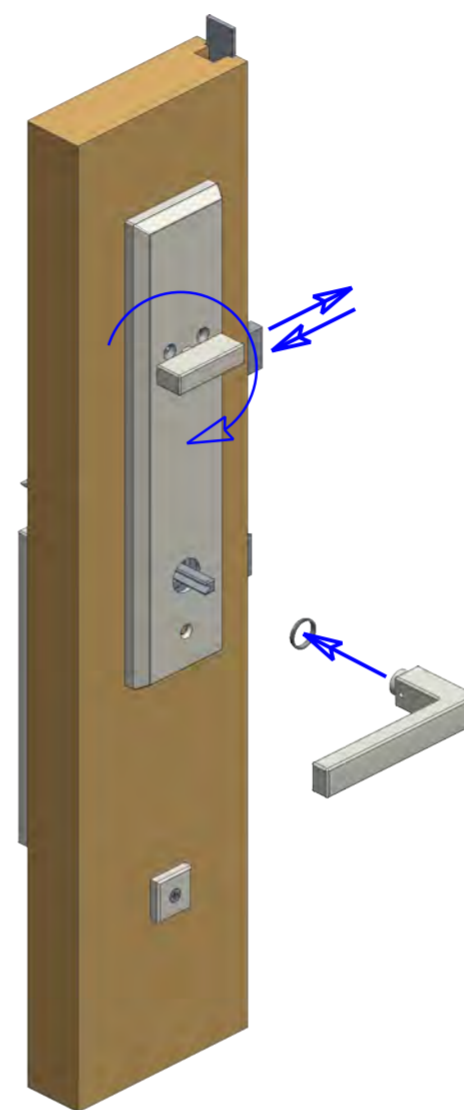

12. Press the lever snugly against the internal plate assembly and tighten the set screw with the provided Allen wrench.

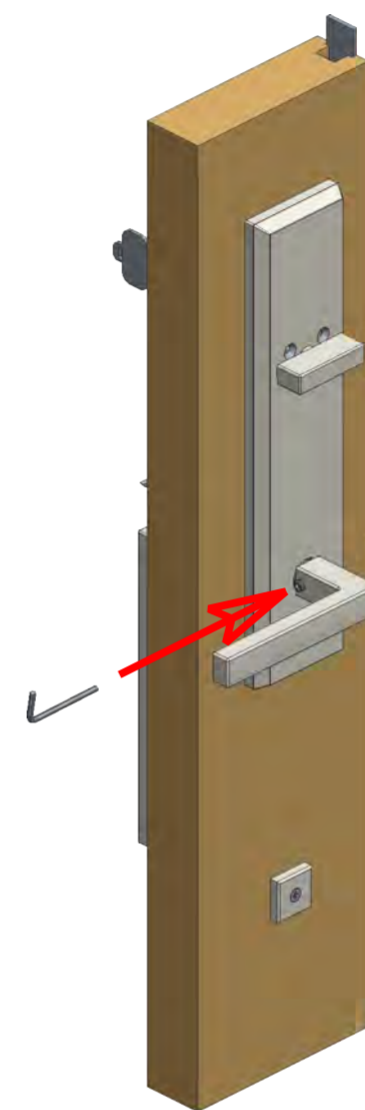

13. Align the internal plate assembly with the edge of the door and mark the position of bottom screw hole locations. Drill a 1/8" pilot hole and secure the internal plate assembly in place with the wood screw on the bottom and the two machine screws on the top or two wood screws.

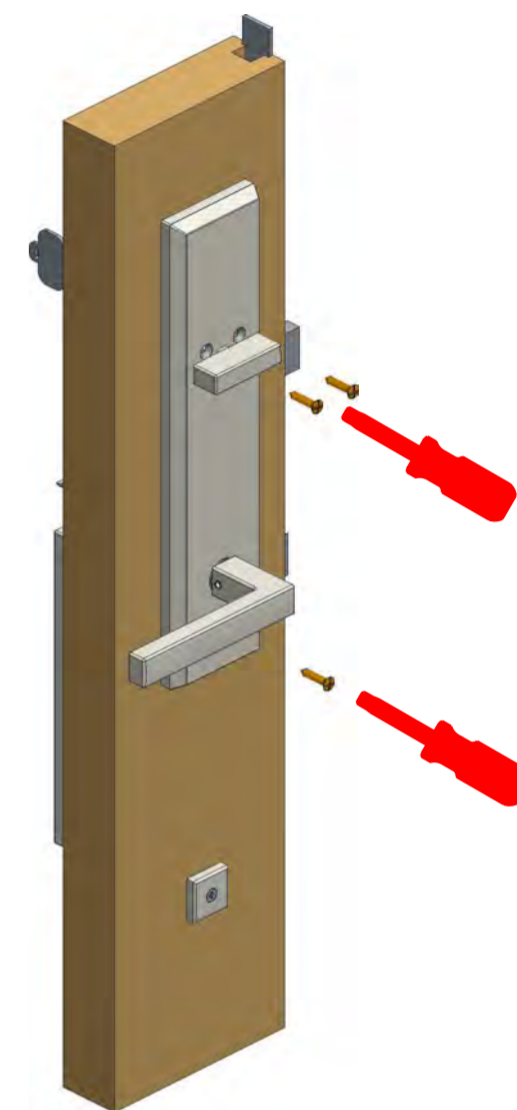

| <b>PROBLEM</b>  | <b>SOLUTION</b>  |
|---|--|
| Can't extend (lock) deadbolt unless key is in cylinder. Can't remove key from cylinder when the deadbolt is extended (locked).                    | Cylinder tailpiece is not oriented properly. Re-install the cylinder by removing the pull assembly. Rotate the cylinder tailpiece 180 degrees and re-install. Refer to steps 6 thru 13.  |
| When thumb grip is depressed or knob/lever is rotated the latch catches and doesn't spring back.  | Ensure door is at least 1-3/4" thick. The latch mounting plate is installed too tight. Referring to step 9, back the two 1-1/2" flathead machine screw out until the latch operates freely. Check whether the spindle collar is causing the latch to bind.   |
| Knob or lever keeps coming off the spindle  | Ensure the spindle is oriented with the groove facing hinge door and the set screw is securely tightened. Refer to steps 5 and 13.   |
| Deadbolt can easily be locked using the interior plate assembly on the inside but is difficult to lock when locked with the key from the outside. | The cylinder is not properly aligned with the interior plate assembly or improper door thickness. Remove the internal plate assembly and loosen the two deadbolt mounting plate screws. Align the cylinder and retighten the deadbolt mounting screws. Ensure your door thickness is at least 1-3/4" thick |
| The thumb grip cannot be depressed to retract the latch.  | Ensure door is at least 1-3/4" thick. The orientation of the hub in the spindle cartridge is incorrect. Remove the handle and re-install refer to step 3 thru 13. Ensure the hub on the spindle cartridge is oriented properly.  |
| Cannot extend deadbolt with the interior plate assembly or key when door is closed.   | Open door and try to extend deadbolt. If deadbolt extends easily with the door open then the strike is not aligned with the deadbolt and/or locking points. Adjust the strike to align with the deadbolt and/or locking points.  |